

GFC SERIES Low ProFile™ 400 Hz AND 270 VDC GROUND POWER UNITS



HORIZONTAL CONFIGURATION

STANDARD FEATURES:

- MIL-STD-704F, ARP 5015, DFS 400 and ISO 6858 Compliant
- Indoor/Outdoor (Hangar/Ramp) Use
- Automatic Input Line Monitoring
- Automatic Line Drop Compensation (ALDC)
- Emergency Mushroom "OFF" Switch
- Dual Output with Individual Safety Disconnect
- Built-in Maintenance Diagnostics
- Analog Control Panel
- Output Voltage and Current Monitoring
- Internal Elapsed Time Meter
- Front Panel Summary Fault Indicators
- 28 VDC, 10 Amp Safety Interlock Power Supply

**This product was manufactured in a plant whose quality management system is registered to ISO 9001:2008.

APPLICATION:

Since its beginning in 1960, Unitron has specialized in the design and development of reliable solid-state power systems for military applications. Through an innovative design, Built-In Test Equipment (BITE) and modular construction, Unitron products assure maximum power availability and minimal repair time for the latest military aircraft including the F-22 A Raptor and the JSF F-35A.

The Low ProFile™ Series includes 400 Hz, 28 VDC and 270 VDC GPUs designed to provide aircraft ground power in "low profile" applications, such as under passenger boarding bridges, in maintenance hangars, or on flight lines. The **dual output AC/DC GPU** provides AC or DC power from a single unit. Because a single unit can do the work of two, Unitron's AC/DC GPU reduces operating and maintenance costs, and saves valuable space in the hangar or on the ramp.

In addition to fixed GPUs, Unitron offers 400 Hz, 28 VDC, 270 VDC and combination AC/DC units in towable, mobile and bridge-mounted configurations.

OPTIONS:

- Alternate Input Voltages Available (specify)
- Input Frequency 50 Hz
- AC and DC Output Power Cables with Plugs at various lengths (specify)
- Front Panel AC and DC Voltage Adjust ($\pm 15\%$)
- No Break Power Transfer (NBPT) Compatible
- 300% AC Overload (dependent on rating)
- Alternate Mounting Configurations Available (mobile, overhead, freestanding/feet and stainless steel forklift tubes)
- Colors: White - Standard, FED-STD-595 - Optional (Specify)
- Built-in Cable Racks

MECHANICAL SPECIFICATIONS:

Size:	See Figure 1
Weight:	30 kW / 37.5 kVA = 815 lbs. (370 kgs.) 48 kW / 60.0 kVA = 900 lbs. (408 kgs.) 60 kW / 75.0 kVA = 970 lbs. (440 kgs.) 72 kW / 90.0 kVA = 1,025 lbs. (465 kgs.)
Construction:	Indoor/Outdoor
Cooling:	Forced Convection

GENERAL SPECIFICATIONS

AC INPUT:

Voltage	480 volts, +10%, -15%, 3Ø, 3 wire plus ground
Frequency	60 Hz ± 10%
Phase Rotation	Any
Protection	Over/undervoltage, loss of phase, overcurrent, short circuit
Inrush Current	No greater than 100% of full load current

AC OUTPUT:

Power Rating	37.5, 60, 75 or 90 kVA (specify)
Overload	150% for 5 min., 200% for 20 sec.
Voltage	115/200 volts, 3Ø, 4 wire, grounded neutral
Voltage Regulation	± 1.0% under all conditions of line, balanced loads and temperature
Voltage Transients	IAW MIL-STD-704E
Frequency Regulation	400 Hz ± 0.01% under all conditions of line, load and temperature
Frequency Transients	None
Phase Angle Regulation	± 2° for balanced loads
Harmonic Distortion	2.0% maximum
Protection	Overload, short circuit, over/under voltage and safety disconnect

ENVIRONMENTAL:

Acoustical Noise	65 dBA maximum at 5 feet
Temperature Range	-40°C to +55°C

DC OUTPUT:

Power Rating	30, 48, 60, or 72 kW dependant upon AC rating
Overload	150% for 5 min. and 200% for 20 sec. at 20% duty cycle
Voltage	270 VDC, 2 wire, grounded negative
Voltage Regulation	<ul style="list-style-type: none"> 100% continuous rated load and ± 10% input voltage ± 0.5% No load to rated load with nominal input voltage ± 1.5%
Voltage Adjust	270 VDC ± 5%
Output Ripple Voltage	< 6 VAC
Transient Response	(25% load changes) IAW MIL-STD-704F
Protection	Overload, short circuit, overvolt- age and safety disconnect

ENERGY FACTORS:

Efficiency	95% typical at full load, 93% typical at half load; varies depending on configuration and rating
Energy Efficiency Ratio	20.0 typical

FIGURE 1

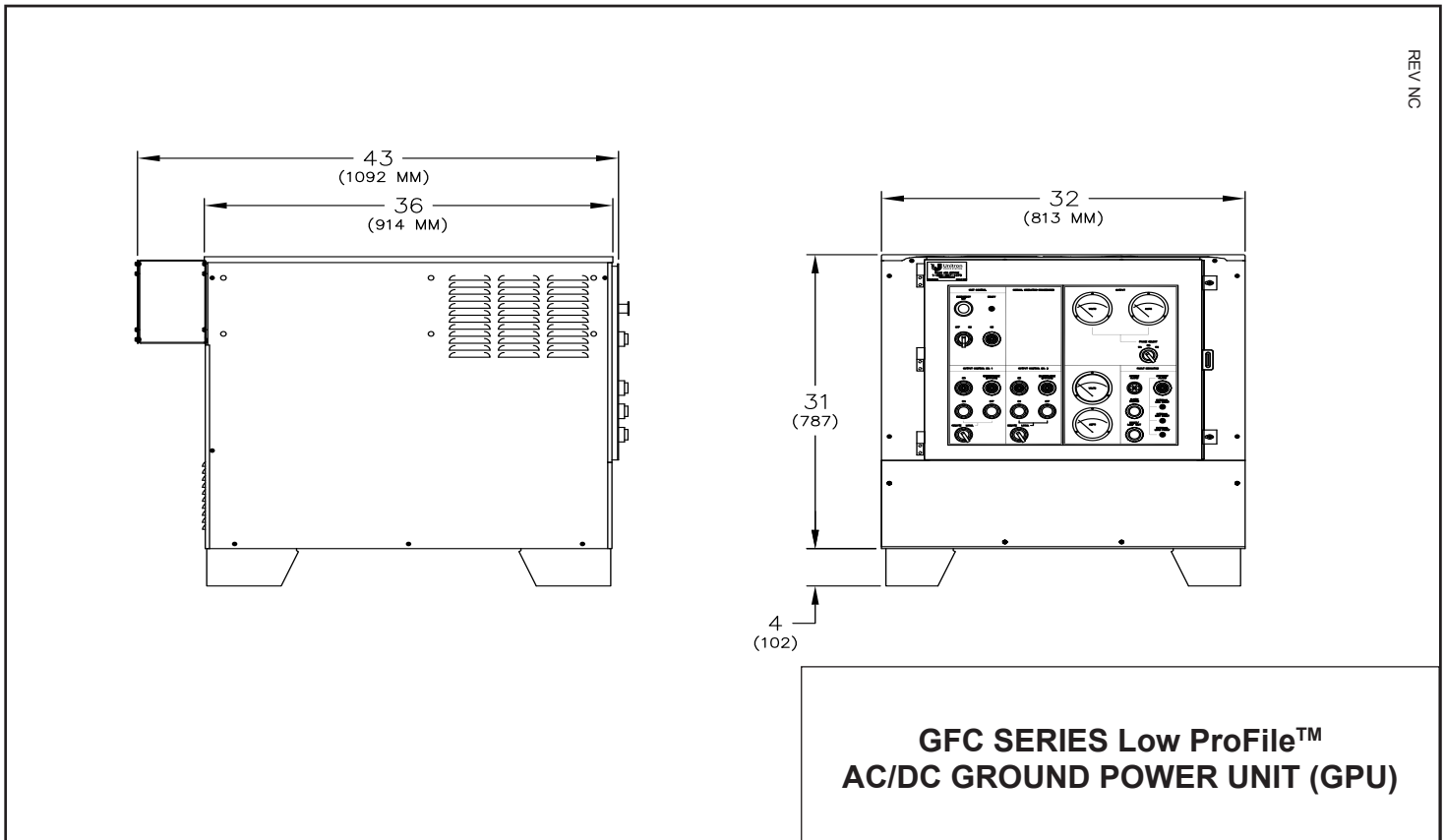

**GFC SERIES Low ProFile™
AC/DC GROUND POWER UNIT (GPU)**

REV NC